



1394 PRINTER WORKING GROUP

**IEEE 1394 HIGH SPEED BUS
IMAGING DEVICE
COMMUNICATIONS SPECIFICATION**

*****PRELIMINARY DRAFT PROPOSAL *****

Revision 0.20-March 19, 1998

Editor -
Alan Berkema

1	Scope.....	3
2	Purpose	4
3	References.....	5
4	Bit, Byte and Quadlet ordering	5
11.	Control & Status Register (CSR) Summary	6
5	Configuration ROM	7
6	Discovery	11
7	SBP-2 Communication Protocol	11
8	ORB List Processing.....	13
8.1	Model (informative).....	13
8.2	Imaging Device Class Model	13
9	Model Configuration.....	13
9.1	Model Operation	14
10	Multiple Host and/or Multiple Device	15
11	Command Block ORBs.....	16
11.1	Configure Data Transfer Size.....	16
11.2	Send Data-in Command	17
11.3	Receive Data-out Command	18
12	Management ORB.....	19
13	Login & Login Response	20
13.1	Negotiated Access Resumption Timeout	20
13.2	Negotiated Transport Alive Timeout	20
13.3	Negotiated Maximum Task Data Payload Size.....	20
13.4	The Extended Access Control Policy -.....	21
13.5	The Login Process -	22
14	Logout.....	25
14.1	Initiator-Explicit Logout	25
14.2	SBP-2 Implicit Logout.....	25
14.3	Initiator Inactivity.....	25
15	Unsolicited Status	25
16	Status Block	26
17	Reconnection.....	29
18	Query Login	30
19	1394 Bus Reset Behavior.....	30
20	Error Recovery.....	31
21	Issues.....	31
21.1	Login.....	31
21.2	Unit Directory	31
21.3	Maximum data size	31
21.4	Unsolicited Status Register Enable	31
21.5	Target Logout.....	31
21.6	Timers	31
21.7	Plug & Play Support	31

1 Scope

This document specifies the communications profile for imaging devices attached to the IEEE 1394 High Speed Serial Bus supporting the imaging device communications command set within the SBP-2 serial bus protocol.

SBP-2 provides multiple, concurrent, independent connections which do not preclude concurrent operation of other protocol stacks; is data, application, and OS independent; and allows for in-order buffer delivery. In order to meet the transport requirements for imaging devices, SBP-2 must be supplemented by a device profile, which specifies:

- a policy to be used for maintaining device access across “transient” link interruptions
- a model of use for maintaining guaranteed, in-order data deliver across “transient” link interruptions
- a command set which supports
 - independent, bi-directional, half-duplex communication
 - data tagging of an associated data payload
 - ability for either end of a connection to close the connection at any time

Information supplemental to the IEEE 1394 and SBP-2 specifications are provided in this document.

This specification does not address:

- Isochronous communication
- Use with 1394.1 bridges.
- Security.

2 Purpose

The purpose of this document is to define the communications specification for IEEE 1394 printers, scanners, digital still cameras and other imaging devices. This specification will include traditional computer host communication to these devices as well as direct peer to peer communication.

The term “image device” is used throughout the remainder of this document to refer to any of the devices listed above.

The primary focus of this document is related to the SBP-2 protocol and how it can be used for image device communication. Requirements are specified to allow imaging device communication conformance to SBP-2. In all areas that concern transport protocol, SBP-2 should be followed. Where SBP-2 allows more than one choice of implementation, this profile defines the choice for imaging devices.

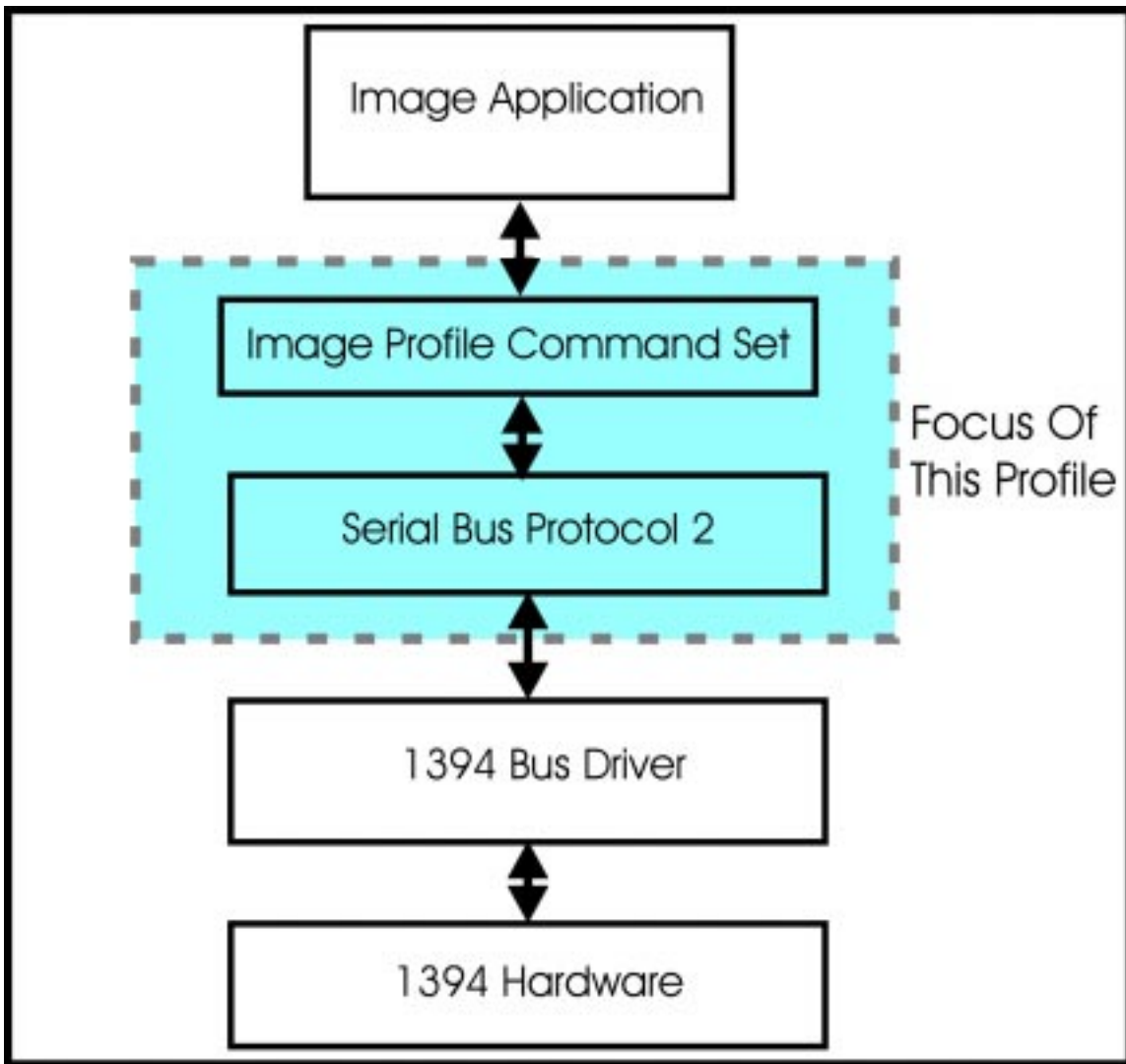

3 References

This document makes reference to and contains excerpts from several industry standards. The revisions of those standards listed are current at the time of this document's release. However, each standard referenced is subject to change. More recent revisions may or may not support the information contained in this document:

1. ISO/IEC 13213 ANSI/IEEE 1212:1994, Control and Status Register Architecture for Microcomputer Buses.
2. IEEE Std 1394-1995, Standard for High Performance Serial Bus.
3. Serial Bus Protocol 2, Revision T10/1155x.
4. Software Design for IEEE 1394 Peripherals, Peter Johansson.
5. New Technology in the IEEE P1394 Serial Bus, Michael Teener, March 29, 1994.
6. P1394a Draft Standard for a High Performance Serial Bus (Supplement).

4 Bit, Byte and Quadlet ordering

This profile defines the order and significance of bits within bytes, bytes within quadlets and quadlets within octlets in terms of their relative position and not their physically addressed position. Within a byte, the most significant bit, msb, is that which is transmitted first and the least significant bit, lsb, is that which is transmitted last on Serial Bus, as illustrated below. The significance of the interior bits uniformly decreases in progression from msb to lsb.

Bit ordering within a byte



Byte ordering within a quadlet

Within a quadlet, the most significant byte is that which is transmitted first and the least significant byte is that which is transmitted last on Serial Bus, as shown below.

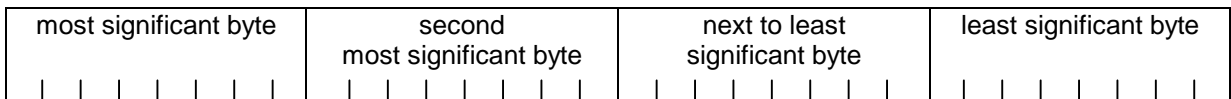

Quadlet ordering within an octlet

Within an octlet, which is frequently used to contain 64-bit Serial Bus addresses, the most significant quadlet is that which is transmitted first and the least significant quadlet is that which is transmitted last on Serial Bus, as the figure below indicates.

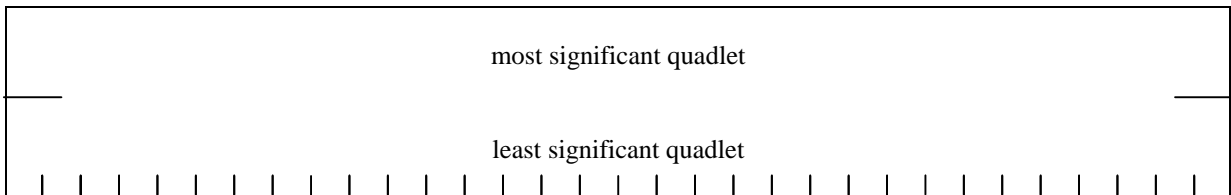

11. Control & Status Register (CSR) Summary

All 1394 PWG devices shall implement the CSRs as defined in ISO 13213/IEEE 1212:1994 and IEEE Std 1394-1995. Note that only the core and BUSY_TIMEOUT would be needed if Isochronous operations are not included. BUSY_TIMEOUT is needed for Asynchronous retry transactions.

Core Registers

Offset	Register	Initial Value
0x000	STATE_CLEAR	
0x004	STATE_SET	
0x008	NODE_IDS	
0c00C	RESET_START	
0x018-01C	SPLIT_TIME_OUT	

Serial Bus Dependent

Cycle Master

Offset	Register	Initial Value
0x200	CYCLE_TIME	
0x204	BUS_TIME	

Other Serial Bus Dependent

Offset	Register	Initial Value
0x210	BUSY_TIMEOUT	

Isochronous Resource Manager

Offset	Register	Initial Value
0x21C	BUS_MANAGER_ID	
0x220	BANDWIDTH_AVAILABLE	4915
0x224-228	CHANNELS_AVAILABLE	All Ones

See the IEEE 1394-1995 specification for detailed information about each register.

Bus Information Block

Offset: 0x404

0x31 "1"						0x33 "3"						0x39 "9"						0x34 "4"					
I	C	I	B	P	resv.	Cyc_Clk_Acc						Max_Rec	reserved 0x00					g	resv.	link_			
R	M	S	M	M																spd			
C	C	C	C	C																			
Node_Vendor_ID												Chip_ID_High											
Chip_ID_Low																							

Taken together the Node_Vendor_ID, Chip_ID_High and Chip_ID_Low are the EUI-64 also known as the Global Unique Identifier (GUID).

Upon detection of a bus reset the generate bit abbreviated as "g" in the bus info block shall be modified if any portion of the configuration ROM has changed since the prior bus reset. The CRC in the first quadlet will be recalculated each time the generate bit is modified.

Root Directory

Offset: 0x414

Directory Length 0x04						Directory CRC (calculated)					
vendor ID key 0x03			Module_Vendor_ID (can be the same as Node_Vendor_ID)								
Module_Vendor_ID _Key 0x81			Module_Vendor_ID_Textual_Descriptor_Offset (indirect offset) 0x03								
Node_Capabilities_Key 0x0C			Node_Capabilities 0x0083E0								
Unit_Directory_Key 0xD1			Unit_Directory_Offset (indirect offset)								

Module_Vendor_ID_Textual_Descriptor

Offset: 0x428

Leaf Length		Leaf CRC (calculated)	
0x41 "A"	0x42 "B"	0x43 "C"	0x08 " "
string continued			
			0x00

Unit Directory

Offset: 0x43C

Unit Directory Length			Directory CRC (calculated)			
Unit_Spec_ID key 0x12	Unit_Spec_ID					
Unit_SW_Version key 0x13	Unit_SW_Version					
Cmd_Set_Spec_ID key 0x38	Cmd_Set_Spec_ID					
Command_Set key 0x39	Command_Set					
Command_Set_Rev key 0x3B	Command_Set_Revision					
Management_Agent key 0x54	Management_Agent_Offset (initial register space offset) 0x4000 (example)					
LU_Characteristics key 0x3A	q	o	I	reserved 0x00	Mgt_ORB_Timeout	ORB_size
Logical_Unit_Number 0x14	reserved 0x00	device_type		Logical_Unit_number 0x00		
Logical_Unit_Model_ID 0x17	Logical_Unit_Model_ID					
LU_Model_ID leaf 0x81	Logical_Unit_Model_ID_Textual_Descriptor Leaf offset (indirect offset)					

Leaf Length 0x04		Leaf CRC (calculated)	
0x41 "A"	0x42 "B"	0x43 "C"	0x08 " "
string continued			

Management_Agent_Register

Address: 0xFFFF F001 0000 (example)

reserved 0x00	ORB_offset_hi
ORB_offset_lo	

The Management Agent Register shall be written using a 1394 Block write with 8 bytes of payload. Even though SBP-2 uses the word offset as part of the ORB address names in ORB_offset_hi and ORB_offset_lo, these values combined with the node ID form an actual IEEE 1394 64-bit address.

Unit Command_Block_Agent CSRs (address is returned in the Login response)

Address: 0xFFFF F001 0008 (example for single Login device)

Relative Offset	Name	Description
0x00	Agent_State	Reports fetch Agent State
0x04	Agent_Reset	Resets fetch agent
0x08	ORB_Pointer	Address of ORB
0x10	Doorbell	Signals fetch agent to re-fetch an address pointer
0x14	Unsolicited_Status_Enable	Acknowledges the Initiator's receipt of unsolicited status
0x18 - 0x1C		Reserved

The Unit Command_Block_Agent CSRs are provided in the Target's memory space. The Address is returned in the Login Response.

6 Discovery

The primary method for discovering devices on the Serial Bus is through information read from the Configuration ROM.

This section will be continued with the Function Discovery Service information supplied by the PWG and IEEE 1212r when this is specified.

7 SBP-2 Communication Protocol

This section is provided to get a general idea of how SBP-2 works. SBP-2 defines a method to exchange commands, data, and status between devices connected to the Serial Bus.

The terms Initiator and Target have a specific meaning derived from SBP-2 and do not imply the direction of data transfer.

Initiator: Originates management & command functions such as Login, data transfer and Reconnect. Provides the shared memory space associated with the management & command functions.

Target: Responds to management & command functions and generates Unsolicited status.

SBP-2 requires that an Initiator login to a Target to begin communication. The basic building blocks of SBP-2 include Operation Request Block (ORB) data structures. The two main types of ORBs are the Command Block ORB and the Management ORB. SBP-2 describes the services that operate on these two types of ORBs as agents.

After power-on or bus reset, the Command_Agent and Management_Agent engines are in the Reset state.

The initiator reads the device's Configuration ROM data in order to determine 1394 capabilities, SBP-2 capabilities, EUI-64 (GUID) value, command set identifiers, software versions, and Management_Agent CSR address.

The initiator performs a Login operation prior to any request to the fetch agent interface. To perform a Login, the initiator writes its Login ORB address to the Management_Agent register.

The device returns the Login response to the bus address specified in the Login ORB. One field of the Login response contains the Command_Block_Agent CSR base address.

Prior to initiating command transfers, the initiator builds a list of Command_Block ORBs in system memory. The list may be as short as one ORB, but this example assumes a list length of more than one. The last ORB in the list contains a NULL Next_ORB pointer, which indicates the end of the list to the device's Command_Agent fetch engine. A NULL address has the n bit (most significant bit) set to a one.

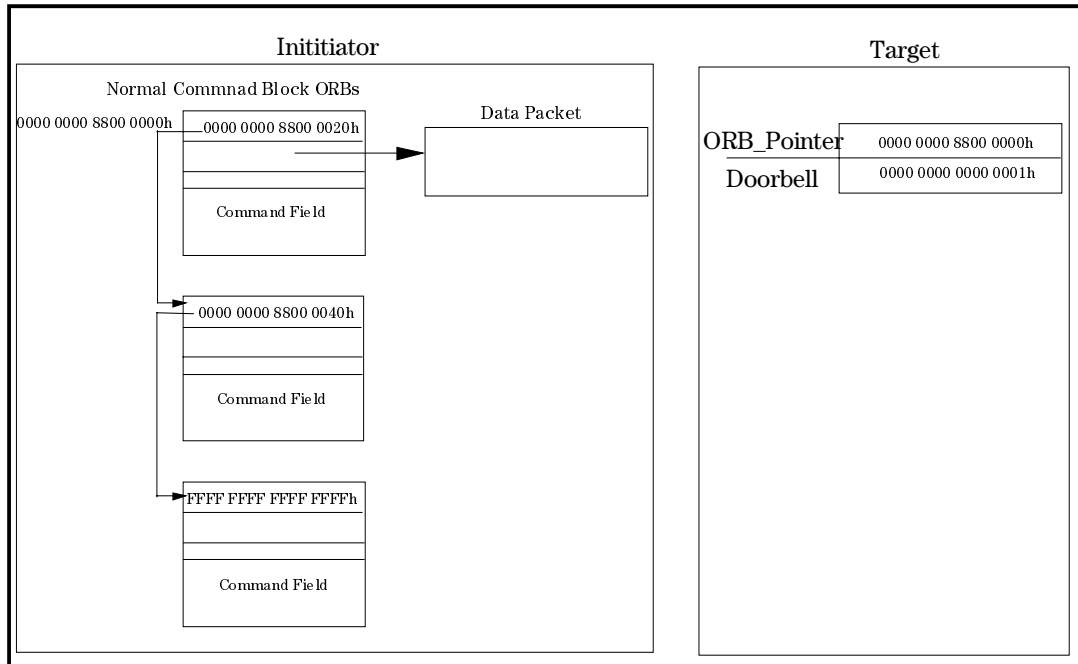

To transition the Command_Agent state from Reset to Active the initiator writes the offset of the first ORB in the ORB list to the device's ORB_Pointer. The ORB_Pointer was discovered through the Command_Block_Agent CSR. This allows the Command_Agent fetch engine to begin fetching ORBs from initiator memory. If the initiator writes to the Doorbell CSR, the device will ignore the Doorbell at this time.

The device may optionally fetch ORBs until its ORB space is full or until an ORB containing a NULL Next_ORB pointer is fetched. Fetched ORBs are routed to the Execution engine. The Execution engine may reorder the execution of the commands contained in the ORBs as long as it can guarantee device integrity.

The Direction bit (d) in the ORB determines the direction of data transfer from the Target's point of view. If the direction bit is zero the Target will use serial bus read transactions to fetch the data from the Initiator. If the direction bit is one the Target will use serial bus write transactions to transfer data to the Initiator. As each ORB is executed the device transfers data in the appropriate direction using serial bus block transactions.

Following the data transfer portion of each ORB the Target writes a Status Block to the Initiator's Status_FIFO address. The Status_FIFO address is the address that was obtained in the Login process. The status block contains SBP-2 specific status information as device-dependant status information.

If an ORB containing a Null Next_ORB pointer is fetched the Execution engine completes all fetched commands, including the one in the just fetched ORB, before the Command_Agent transitions to the Suspended state.

If additional commands are to be executed, the initiator creates a new list of Command_Block ORBs; changes the Next_ORB pointer in the last ORB of the old list from NULL to the offset of the first ORB in the new list and then writes to the device's Doorbell CSR address. This transitions the Command_Agent to the Active state.

The device fetches the new Next_ORB pointer value from the last ORB of the old list and begins fetching ORBS from the new list at that offset.

If the Command_Agent fetch engine has not reached the ORB containing a Null Next_ORB pointer, (and is still in the Active state) the device ignores any writes to the Doorbell CSR address.

This sequence may continue until the device is reset, power is removed, or an error occurs.

8 ORB List Processing

This specification defines the basic communication path as a Login from an Initiator to a Target. The service that an Initiator logs into is represented by a Unit Directory. An instance of that service is represented by a logical unit. A Target may have more than one Unit Directory. A specific Initiator is only allowed one Login per logical unit on a specific Target

For a given Login the Initiator provides a single linked list of ORBs called the task list and the Target fetches ORBs from this task list.

8.1 Model (informative)

This section describes the model of use of SBP-2 and the extensions provided by this profile. Though the features are application independent, this section describes the intended range of the imaging device class in order to better understand the communications provided by this profile.

8.2 Imaging Device Class Model

The imaging device class is intended to support devices which provide either image source or image sink capability. They are characterized by:

Requiring data integrity be maintained

Devices carry internal modifiable state information which is limited to an access session (i.e. job- or session-oriented)

An access session may span a long time (in human terms)

Physical device status exists which is outside the scope of the image source or image sink service but may reflect the devices (temporary or permanent) inability to complete the requested operation.

These devices generally include scanners, printers, and digital still cameras. Each device is modeled as providing at least one image source or image sink service, a device status service, a device control service, and zero or more applications which can use these same types of services on other devices.

9 Model Configuration

Each service is built upon this communications profile and is characterized by the following parameters:

Data packet vs. Data stream based communications model
image source, image sink, status, or control type service
transport client command set supported

Each unique combination of the above information represents a unique service provided by the device and is identified as a separate Unit within the device. Zero or more instances of a unit may exist within the device at any given time. All instances of a unit have identical functionality. Each instance of a unit is uniquely identified by a logical unit number assigned during login. LUNs are assigned upon successful login in numerically ascending order beginning with zero. A login request of a LUN which is already assigned shall return a response code of (4) access denied. A login request of a LUN which is unassigned, but unsuccessful due to resources shall return a response code of (8) Resource unavailable.

The Unit Directory shall not enumerate each LUN which may be supported.

9.1 Model Operation

The initiator reads the device's Configuration ROM data in order to determine its 1394 capabilities, SBP-2 capabilities, EUI-64 value, command set identifiers, software versions, and Management_Agent CSR address for each service provided.

The Initiator performs a Login operation prior to any request to the device. This login process conforms to the SBP-2 specification, and is extended to determine the following information:

Access Resumption Timeout - an extended timeout on access reservation to the service interface. This is needed for support of transient link interruptions.

Transport Alive Timeout - used to determine that the initiator's transport layer has failed in such a way that no indication (e.g. Bus Reset) is generated. This is a response timeout for a "ping" type of request from the target.

Maximum Task Data Payload per direction - used to determine the largest data payload transferable in each direction. The transfer must be completed and acknowledged before being passed along to the receiving transport client. This is needed to provide data integrity across Bus Resets and transient link interruptions.

The initiator is required to enable unsolicited status from the target. The unsolicited status field is used by the device to indicate when new target to initiator data is available and no task was detected on the request list for receiving the data. This is used as an early indication that data is available. If the target finds itself in a deadlock situation and cannot continue processing the requests in order, the target shall abort all data transfer requests and let the initiator reissue the requests to receive data into the initiator. It is also used by the target to request the initiator to confirm that the initiator's transport stack is still responsive.

All data transfers within a specific direction between the initiator and the target are limited to the Maximum Task Data Payload negotiated for that direction. In Buffer mode, a data buffer shall be limited to the Maximum Task Data Payload negotiated for that direction. Each data payload shall contain exactly one buffer.

All data payloads for a specific direction are processed in the order queued on the task list. Since out-of-order completion and removal of ORBs from the middle of an active task list is not addressed by the SBP-2 specification, the out-of-order task list execution model is too vague and too limited to be an option. So, all task list processing shall use the ordered execution model.

Every command shall have the ORB notify bit set to one. The data transfer commands shall not be considered complete until successful completion notification has been given.. This is necessary to avoid duplication of the commands in the data stream.

The target shall report Data Available to the initiator whenever data exists to go to the initiator. If the target reaches a deadlock condition where it cannot process the data transfer into the target until it can send data to the initiator, the target shall abort all tasks on the task list after reporting Data Available to the initiator. Upon a Bus Reset, all tasks on the task list are implicitly aborted. Because no data is sent to the receiving transport client until the task has been successfully completed, neither a Bus Reset nor a task set abort can corrupt the data. All requests for data from target by the initiator shall be the Maximum Task Data Payload size negotiated for target to initiator data.

Upon a Bus Reset, the SBP-2 reconnection process shall be followed. A successful reconnection shall be transparent to this profile. Upon the timeout of the reconnection window, the extended access control policy shall take effect and reserve the logical unit number and service interface for the initiator until the extended timeout expires. During this time the internal server state shall be retained. Upon expiration of the extended access control policy, the access reservation ID shall become invalid for another extended access control timeout interval.

The communications profile command set consists minimally of:

Receive from Initiator - transfer data payload to the target
The command carries a tag for indicating end of data for connection, and a tag for indicating the data payload carries out-of-band data.

Send to Initiator - transfer data payload from the target
The command carries a tag for indicating end of data for connection, and a tag for indicating out-of-band data, and a field for indicating amount of valid data sent to the initiator.

Reserved - reserved for future extensions

The initiator shall close a connection by an explicit logout command to the target's Management_Agent register. The initiator shall not retain access to the device when it is not actively using the resource.

The process used by the target to close a connection shall be by aborting the current task set with a status of (10) Login ID not recognized. If no task set exists, and the unsolicited status enable register is set to a one to allow an unsolicited status message to be sent, then an unsolicited status message shall indicate that a spontaneous logout was performed. If neither condition exists when the target wishes to terminate the logout, then the initiator must infer the connection being closed upon the next interaction with the target. The target shall not wait for confirmation of the logout before releasing resources.

10 Multiple Host and/or Multiple Device

There is a need to provide fair access to devices on a 1394 bus. Each node is accessible from any of the other nodes on the bus and possibly nodes outside of the bus in a bridged environment. It is reasonable to expect that more than one initiator node may attempt to communicate with a target service at the same time.

SBP-2 provides a Login function. A successful Login creates a connection between two nodes. This creates the required instance data within the target memory. Devices that conform to this profile are required to support a minimum of a single Login. A specific implementation may support multiple logins and arbitrate between them.

11 Command Block ORBs

All devices that conform to this communications profile shall support the Normal Command Block ORB. The *command_block* field of the Normal Command Block ORB shall be exactly 12 bytes.. The format of the ORB shall follow the SBP-2 specification. The *command_block* field shall follow the format below.

Command Block ORB

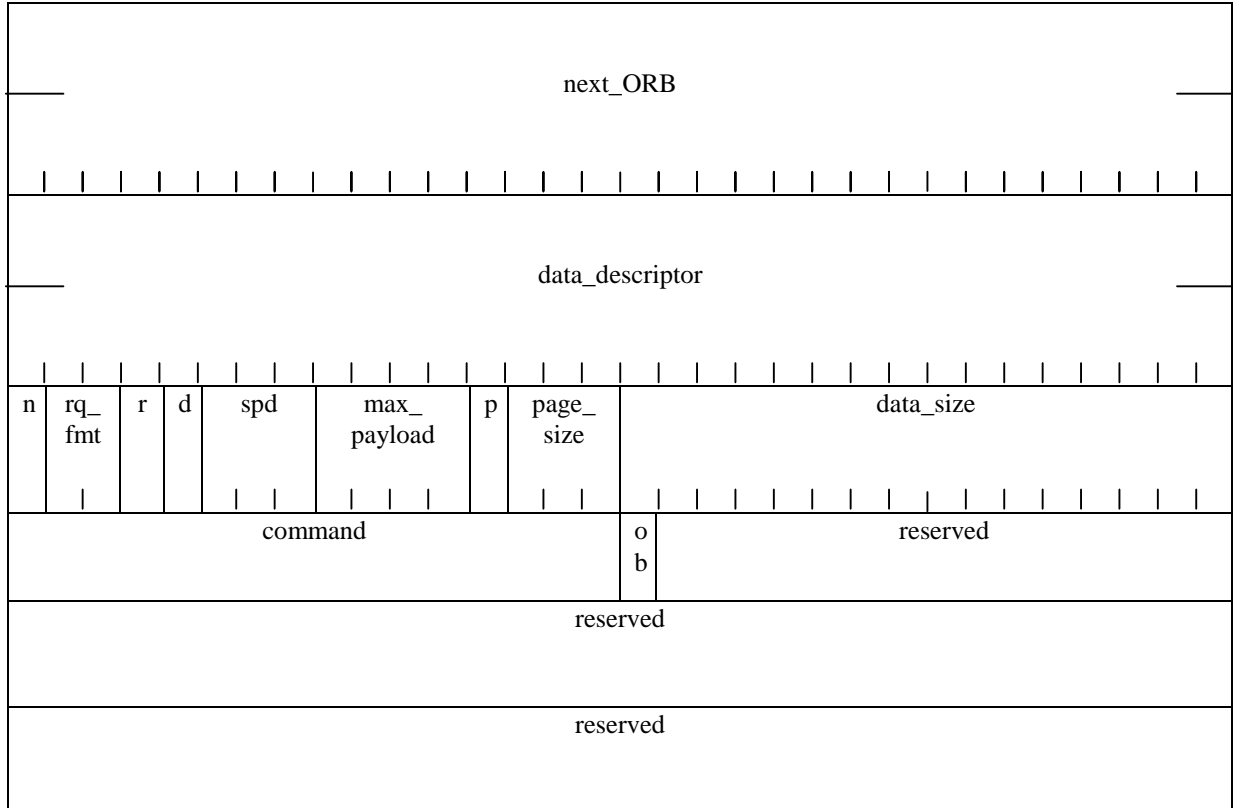

The Command field (? bits) shall be encoded as follows. All unspecified values are reserved for future use.

Command Code	Description
??	Configure data transfer size
??	SND data in - transfer data block from target to initiator
??	RCV data out - transfer data block from initiator to target

11.1 Configure Data Transfer Size

11.2 Send Data-in Command

The Send Data-in command requests the target to store up to the requested data size (or one packet if in packet mode) into the referenced buffer. The buffer shall be able to contain up to the negotiated target to initiator Max Data Payload Size. The amount of valid data stored shall be returned in the status block for the request. The status block shall be written only after the data payload is valid for the return status. Successful completion of the status block write shall indicate completion of the command.

`data_size` specifies the number of bytes
 Data descriptor buffers shall be limited to 2^{20} bytes.

The `ob` field (out-of-band) shall be treated as a reserved field with respect to the Send Data In command.

The status block shall indicate if additional data is available for the initiator as of the time of completion of the command.

Send Data In Response Format - This is the command set-dependent part of the Status Block. See the Status Block section for greater detail on the status block.

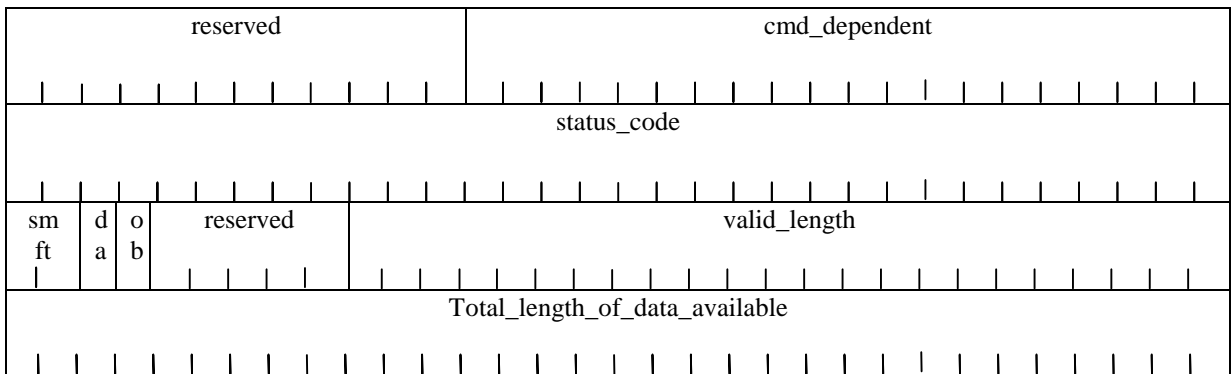

smft Code	Description
0	Normal command response format
1-2	Reserved
3	Unsolicited Status response format

da - Data Available Code	Description
0	No target data exists for initiator
1	More Target data exists for the initiator

smft - field shall specify the format of the status block. The table below defines permissible values for *smft*.
ob - out-of-band tag. Shall be set to one by the target if the data transferred has been identified as out-of-band data, and shall be set to zero otherwise.

da - Is used for status after completion of the ORB. The *data_avaiible* field shall indicate whether or not data is available for the initiator at the time the command was completed. A value of zero shall indicate that data is not available. A value of one shall indicate that data is available.

valid_length - amount of valid bytes transferred to the data descriptor buffer

11.3 Receive Data-out Command

The Receive Data-out command requests the target to store the referenced data into the target's input buffer. The buffer shall be no larger than the negotiated initiator to target Max Data Payload Size. The amount of valid data to store is encoded as per the SBP-2 specification . The status block shall be written only after the data payload is valid for the return status. Successful completion of the status block write shall indicate completion of the command.

Data payloads shall be limited to 2^{20} bytes.

The ob field (out-of-band) shall be set to one if the data is tagged as out-of-band by the transport client, and shall be set to zero if the data is not tagged as out-of-band by the transport client.

The status block shall indicate if data is available for the initiator as of the time of completion of the command.

Receive Data Out Response Format - This is the command set-dependent part of the Status Block. See the Status Block section for greater detail on the status block.

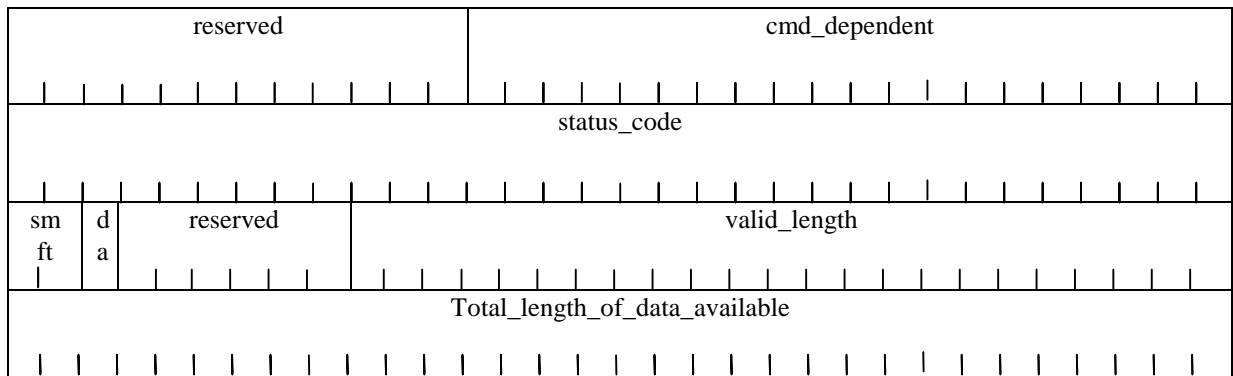

smft Code	Description
0	Normal command response format
1-2	Reserved
3	Unsolicited Status response format

da - Data Available Code	Description
0	No target data exists for initiator
1	More Target data exists for the initiator

smft- field shall specify the format of the status block. The table below defines permissible values for *smft*.
da - Is used for status after completion of the ORB. The *data_avaiible* field shall indicate whether or not data is available for the initiator at the time the command was completed. A value of zero shall indicate that data is not available. A value of one shall indicate that data is available.
valid_length - amount of valid bytes transferred to the data descriptor buffer

12 Management ORB

All information within this section of the SBP-2 specification apply.

1394 asynchronous imaging devices shall implement the following Management ORB functions:

Table 12 - Management ORB Functions Support List

Function Value₁₆	Management Function	Support Level
0	Login	Required full support
1	Query Login	Required full support
2	Create Stream	Understood - unsupported functionality
3	Reconnect	Required full support
4	Set Password	Understood - unsupported functionality
5 - 6	Reserved	Required full support
7	Logout	Required full support
8 - 9	Reserved	Required full support
A	Not Supported	Required full support
B	Abort Task	Required full support
C	Abort Task Set	Required full support
D	Clear Task Set	Understood - unsupported functionality
E	Logical Unit Reset	Required full support
F	Target Reset	Required full support

13 Login & Login Response

This section will specify the details of the Login Process.

The primary reasons for Login are access control, unsolicited status and the simple SBP-2 reconnect scheme.

In order to meet the requirement that this communications profile is tolerant of transient link interruptions, this requires that access control to the device is maintained across the interruptions. Since these interruptions may last longer than the explicit one second reconnect timeout specified by SBP-2, The following issues must be addressed.

- Extending the Access Control (login/reconnect) Service
- Allowing the target to determine when the initiator is no longer operational
- Guaranteeing data transfers are independent of transport client processing

This requires additional information to be passed with the Login ORB and shall be encoded absolutely in the password field. The response information shall be appended to the end of the Login Response structure and shall be included in the length field of that structure.

13.1 Negotiated Access Resumption Timeout

Initiators and targets negotiate for the maximum commonly supported access resumption timeout. Since the nature of the feature is to support transient link interruptions (in human terms), the specified maximum access resumption timeout is limited (arbitrarily) to 5 minutes. The supported maximum is implementation-dependent.

The target shall retain sufficient information to allow each initiator to regain service access (and any associated context) for the negotiated timeout subsequent to an implicit logout due to a missed reconnect . Access may be resumed with a keyed login request. Once the access has been resumed, the LUN's timer shall be stopped and reset. After the timeout expires, the target shall release access to the service and shall perform an implicit logout for all login ID's that have not been successfully reconnected to their original initiator(s).

When the initiator explicitly issues a logout command for the session, the resources shall be immediately released.

13.2 Negotiated Transport Alive Timeout

It is desirable for a target to be able to detect that the initiator stack is not functioning in such a way to cause a Bus Reset event. This is beneficial to help release the resources accessed by the initiator. This leads to a need to negotiate an initiator response interval to an unsolicited status transfer. This may be used by the target to "ping" the initiator when it needs to recover resources. The target shall ping the initiator by issuing an unsolicited status message indicating the current status. If the initiator does not issue additional unsolicited status credit within the negotiated timeout, then the login shall be invalidated by the target, and access to the device shall be released.

If Unsolicited Status credit does not exist, the target shall wait for one negotiated timeout interval for indication of initiator activity. If unsolicited status credit still does not exist, the initiator will be automatically logged out by the target, access control to any interfaces or state maintained by this service will be released, and the service will become generally available on the 1394 bus.

13.3 Negotiated Maximum Task Data Payload Size

Because a Bus Reset implicitly aborts all tasks in the task list(s), and the data payloads are not idempotent (they hold state information), data block transfers between initiator and target must be completed and verified before being presented to the applications. This requires data payload sizes be limited to the buffering available on each end for each direction of data transfer. absolute buffer sizes shall be negotiated in units of 128 bytes.. The maximum byte size supported shall be limited to 2^{20} bytes.. Sizes must be negotiated per direction. The details of this scheme are specified in the Password field of the Login ORB and as an extension to the Login Response ORB in the following sections.

13.4 The Extended Access Control Policy -

The login protocol shall be extended as follows:

For each logical unit, an additional `access_control_descriptor` shall hold context required to extend the access control policy. This context consists of the `access_owner_EUI_64`, a `access_owner_ID`, and the access control negotiated parameters.

The `access_owner_EUI_64` is the unique 64-bit identifier of the current owner of access to the application. Upon a power reset, the `access_owner_EUI_64` for all `access_control_descriptors` shall be reset to all ones. Upon expiration of the `access_release_timeout` plus one second, or upon an explicit successful logout by the initiator, the `access_owner_EUI_64` shall be reset to all ones.

Before an initiator may signal any other requests to a target it shall first perform a login. The login request shall follow the process described in the SBP-2 protocol. The target shall additionally validate a login request as outlined below:

If the logical unit's `access_owner_EUI_64` field is not set to all ones, then:

If the logical unit's `access_owner_EUI_64` field does match the EUI-64 of the initiator, then:

if the `access_owner_ID` does not match the `access_owner_ID` supplied in the Login ORB, then the target shall reject the login request;

If the negotiated values do not match those stored in the `access_control_descriptor`, then the target shall reject the login request;

Upon successful validation of the login request, the target shall

Reset the service associated with the requested logical unit if and only if the initiator's EUI-64 does not match the value stored in the `access_owner_EUI_64` field;

Subsequently store the initiator's EUI-64 value in the `access_owner_EUI_64`;

Assign an `access_owner_ID` for this session;

compute the minimum `access_release_timeout` value between the timeout requested by the initiator and the maximum timeout supported by the application, store this timeout value in the `access_control_descriptor`;

Compute the negotiated `maximum_data_payload_size` for each direction (initiator to target and target to initiator) between the sizes requested by the initiator and those supported by the target, and store these in the `access_control_descriptor`

Compute the minimum initiator_inactive_timeout value between the timeout requested by the initiator and the maximum timeout supported by the application, and store this timeout value in the access_control_descriptor;

Finally return the access_owner_ID, the access_release_timeout, the maximum_data_payload_size for each direction, and the initiator_active_timeout as specified in the ammended Login response descriptor specified in section ???

13.5 The Login Process -

- 1) The Initiator will discover a device by reading the CSR & Configuration ROM space of all devices on the 1394 bus.
- 2) The Management_Agent_Register is also discovered at this time.
- 3) The Initiator will record the Target's GUID.

Login ORB

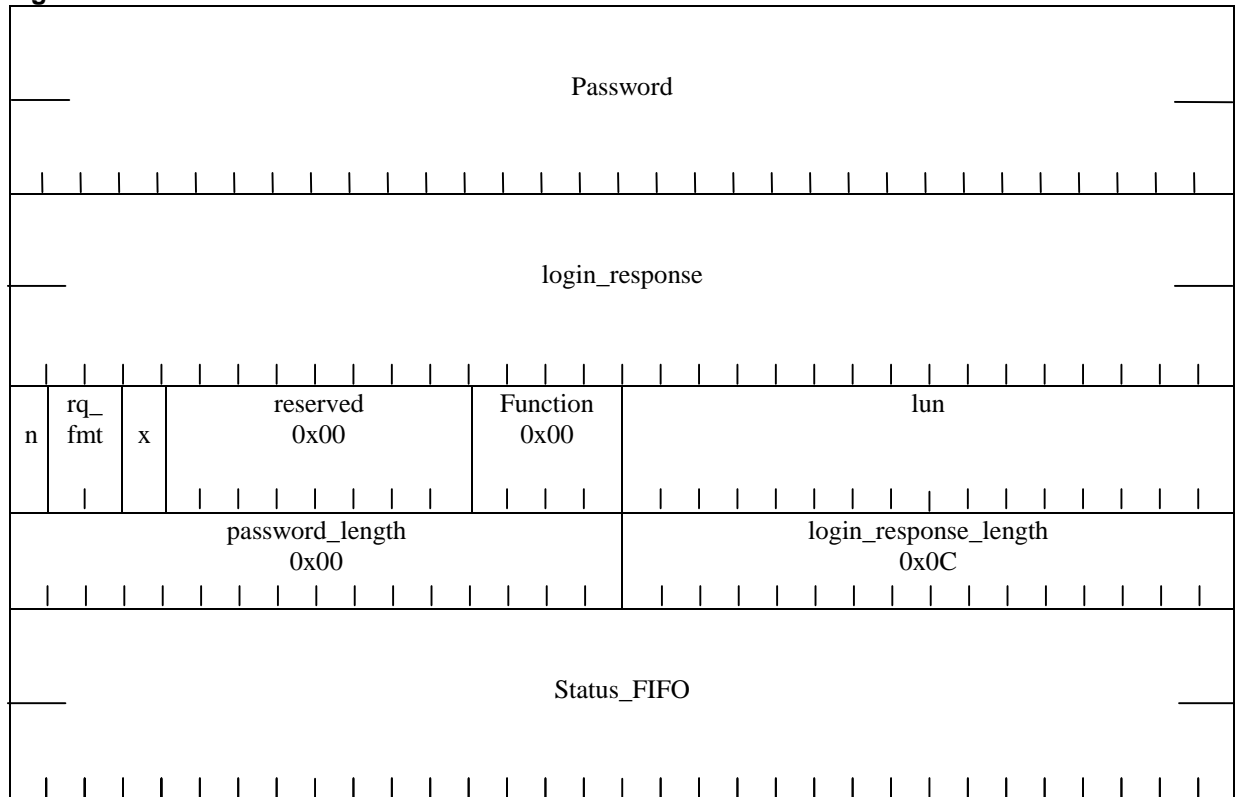

- 4) The Initiator will build the Login ORB with or without a password.
- 5) The login_response address is the temporary memory address that the Target will use to send its response to the Login.
- 6) The Status_FIFO address will remain static during the life of the Login.
- 7) The Initiator will write the address of the Login ORB to the Target's Management_Agent register. [Target shall monitor writes to this address or set up an Interrupt]
- 8) The 1394 speed (s100, s200, s400) of the write to the Management Agent register will determine the speed used for communication.
- 9) The Target will read the Login ORB.
- 10) The Target will read the Initiator's bus information block to discover the GUID.

- 11) The Target will validate this new Login by comparing the GUID against current login_descriptors. If this Initiator is already logged in the Login shall be rejected. If the Target only supports one Login and another device is logged in, the Login shall be rejected.

During the login process the initiator shall provide the access_owner_ID assigned to the previous login (if resuming access), or shall use the value of zero to request a new access. The target shall attempt to validate the request, and shall reject it if the access cannot be given. The

- 12) The Target will build a login_descriptor data structure that will be associated with this specific login.
- 13) The Target will store the Initiators GUID in the login_descriptor login_owner field.

Login Response ORB

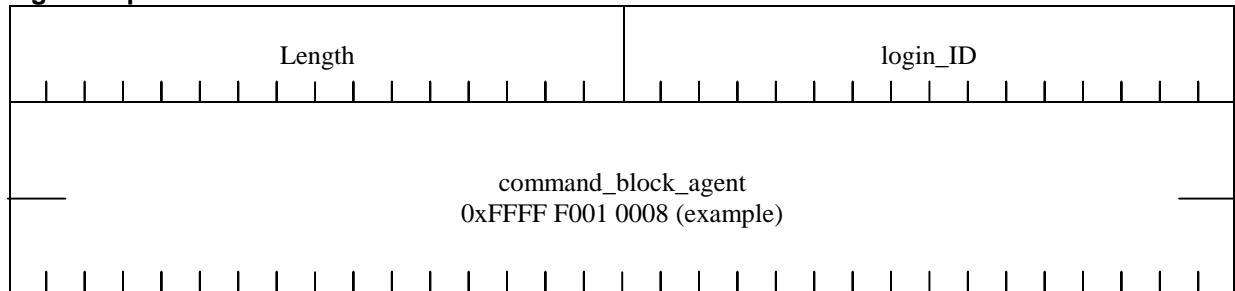

- 14) The Target will build the Login Response ORB and fill in the login_ID. The login_ID is like a connection identifier that is unique across active Logins.
- 15) The Target will store the login_ID in the login_descriptor.
- 16) The command_block_agent address points to the Unit Command_Block_Agent CSRs in the Configuration ROM.
- 17) Finally the Target writes the Login Response ORB to the login_response address.

Writing “resources_unavailable”, in the sbp_status field of the status block, to the Login’s Status_FIFO address will reject a Login.

The *login_response_length* shall accommodate of the size, in bytes, of the Login Response specified in this standard.

The Login response shall be extended by one quadlet. This quadlet shall be of the same format as described above. The information shall be the minimum values between what the initiator desires and what is the maximum supported by the target for this service.

Initiator to Target Data Payload limit - This is the maximum data payload size supported for confirmed initiator-to-target data transfers. The value is in 128-byte units.

ntat - Negotiated Transport Alive Timeout. This is the timeout used by the target to determine that an initiator is no longer functional. It waits this amount of time for the initiator to respond to an unsolicited status transfer by giving additional unsolicited status credit.

Table XXX - Negotiated Transport Alive Timeout Code

Reconnect Timeout Code Field	Duration (seconds)
0 ₁₆	100 (msec)
1 ₁₆	200 (msec)

2_{16}	500 (msec)
3_{16}	1
4_{16}	3
5_{16}	5
6_{16}	10
7_{16}	15

Target to Initiator Data Payload Limit - This is the maximum data payload size supported for confirmed target-to-initiator data transfers. The value is in 128-byte units. All requests for data transfers from the target shall be of this size. The target may return less than the requested information.

nant - Negotiated access resumption timeout. This is the extended time allowed by the target for an initiator to reestablish a login to a service after failing to reconnect in sufficient time.

Table XXX - Negotiated Access Resumption Timeout Code

Reconnect Timeout Code Field	Duration (seconds)
0_{16}	0
1_{16}	5
2_{16}	10
3_{16}	15
4_{16}	30
5_{16}	60 (1 min)
6_{16}	120 (2 min)
7_{16}	300 (5 min)

14 Logout

14.1 Initiator-Explicit Logout

Upon an explicit logout by the initiator, access shall be immediately released by reinitializing the `access_control_descriptor`.

14.2 SBP-2 Implicit Logout

Upon detection of an implicit logout by SBP-2, the `access_release_watchdog` shall start. This watchdog shall only be stopped by its expiration or a revalidated access. Access only needs to be revalidated after an implicit Logout.

14.3 Initiator Inactivity

Upon expiration of the `transport_alive_timeout`, the target shall implicitly logout the initiator and immediately release resources. The conditions which cause the target to start the `transport_alive_timer` are beyond the scope of this document.

15 Unsolicited Status

All unsolicited status generated by this specification shall reflect communication status only. No device-specific or service-specific information shall be carried in the unsolicited status message. The unsolicited status message shall be identified by setting the `src` field to a value of two (indicating the source is “device” status). When an unsolicited status block is stored as a result of initiator inactivity, the status structure shall indicate the nature of the request, and shall also indicate the current state of transport status.

1. The Target shall clear its `Unsolicited_Status_Enable` register after a successful Login.
2. The Initiator shall write a one to the Target's `Unsolicited_Status_Enable` to allow Unsolicited Status.
3. The Target may send Unsolicited status, using a Status Block, to the Initiator using the `Status_FIFO` address that the Target received during Login.
4. The Target shall use its `Unsolicited_Status_Enable` register to handshake this status block.
5. The Target can only store status when the `Unsolicited_Status_Enable` register is set to one.
6. After writing the status, the Target shall clear this register.
7. The Initiator shall write a one to the Target's `Unsolicited_Status_Enable` to allow subsequent Unsolicited Status.

The reason for the handshake for the Unsolicited status is because of its unsolicited nature. The initiator when preparing a FIFO to receive status knows how many ORB's it has given or will give to the target. The Initiator can allocate enough FIFO for those status reports. Since the Initiator does not know how many Unsolicited reports it may receive it is required to allocate at least one FIFO location and use the handshake with `Unsolicited_Status_Enable` when that one is available.

resp field

Value	Name	Description
0	REQUEST COMPLETE	The request completed without transport protocol error (Either sbp_status or command set-dependent status information may indicate the success or failure of the request)
1	TRANSPORT FAILURE	The target detected a nonrecoverable transport failure that prevented the completion of the request
2	ILLEGAL REQUEST	There is an unsupported field or bit value in the ORB; the sbp_status field may provide additional information
3	VENDOR DEPENDENT	The meaning of sbp_status shall be specified by this specification

sbp_status field

Value	Description
0	No additional sense to report
1	Request type not supported
2	Speed not supported
3	Page size not supported
4	Access denied
5	Logical unit not supported
6	Maximum payload too small
7	Too many channels
8	Resources unavailable
9	Function rejected
10	Login ID not recognized
11	Dummy ORB completed
12	Request aborted
0xFF	Unspecified error

17 Reconnection

Reconnection after a Bus Reset will be accomplished using the Reconnect ORB.

A successful reconnection shall be interpreted as initiator activity, resulting in the initiator_inactive_watchdog being reset and restarted..

Reconnect ORB

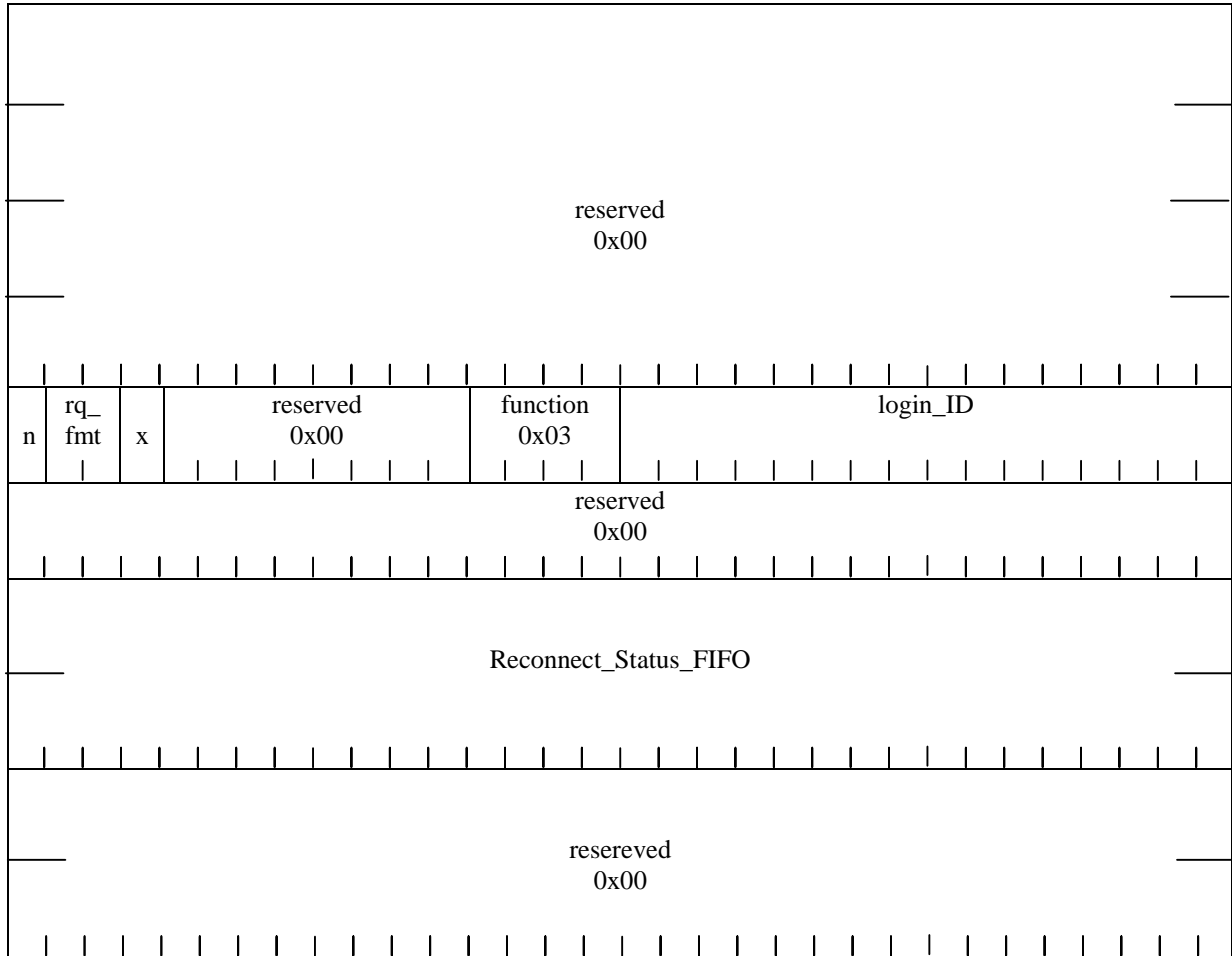

1. After a bus reset, the Initiator is required to re-discover the Target that it was Logged into by reading the Bus Information Blocks of nodes on the bus searching for a matching GUID.
2. After a bus reset, if the Target was connected by a Login the, Target will start a timer. The SBP-2 specification suggests 2 seconds, we may want to tune this value.
3. Once the Target is found the Initiator can write the address of the reconnect ORB to the Target's Management_Agent register.
4. The 1394 speed (s100, s200, s400) of this write will determine the speed used for communication.
5. The Initiator shall use the same login_ID that the Target provided at Login. The Target will fetch the reconnect ORB and read the Initiators Bus Information Block to verify that the Initiators GUID match the GUID established at Login.
6. The reconnect is completed when the Target writes status to the Reconnect_Status_FIFO. Note that this is a new separate Reconnect_Status_FIFO, which is not the same Status_FIFO established at Login.

7. After reconnect the 48 bits of the Login Status_FIFO is used for unsolicited status.
8. The Login Status_FIFO address may have to be patched with the Initiators new node number and bus number.
9. The Data_FIFO_Addresses may also have to be patched with the new Node number and Bus number.
10. If the Target's timer expires before a reconnect ORB is provided the Target will perform an automatic Logout. Logout consists of resetting the login descriptor variables to their initial values. The Unit Command_Block_Agent CSRs should also be reset to initial values.

A special case occurs when an active Login exists between an Initiator and a Target if the Initiator is power cycled independent of the Target. After the bus reset the Target is expecting a Reconnect and the Initiator will attempt a new Login. The Target shall refuse the Login if it happens before the Targets timer has expired. Initiators shall retry the Login after waiting a timeout period.

18 Query Login

19 1394 Bus Reset Behavior

Upon a Bus Reset, the initiator_inactive_watchdog shall be reset and restarted to allow a window for the initiator to re-establish the connection and give permission for the target to issue an Unsolicited Status message.

After a Bus Reset:

During idle state - no data transactions pending

Reconnect as described in preceding section.

During Asynchronous data transmission

Reconnect as described in preceding section and continue data phase.

During Isochronous data transmission

Continue with Isochronous data transmission.

20 Error Recovery

Asynchronous Data Transmission Error Recovery

Any packet, which contains a CRC error, shall be re-transmitted when the error_ACK is returned to the sender.

21 Issues

21.1 Login

Microsoft has implemented their SBP-2 driver to do a login on power up and not logout until the PC is shut down. Though this is provided for within the SBP-2 specification, it requires devices, which may be shared among multiple PCs to support multiple logins to a single service, even if the different PCs cannot simultaneously use the service.

Can imaging devices (which want to take advantage of the shared nature of 1394) tolerate the resource requirements to operate on a multiple Microsoft O/S host configuration?

21.2 Unit Directory

How to encode the following information in the Unit Architecture and Directory Structure?

Transport client command set information?

Data packets vs. Data stream communications model?

transport client class of service? (Printing vs. Scanning vs. ???)

21.3 Maximum data size

Current proposal is 1 Mega byte. Discussion?

21.4 Unsolicited Status Register Enable

Need policy for Initiator to always do this ASAP.

21.5 Target Logout

How does a Target Logout?

21.6 Timers

Need explanation of behavior at initialization and reset

21.7 Plug & Play Support

Should the discovery section contain information about Plug-N-Play support?

Appendix A - SBP-2 Extended Access Control Policy Proposal

The issue of a fixed access control limit imposed by SBP-2 reconnects presents a generic problem to devices, which do not use isochronous services and want to tolerate transient link interruptions. Therefore, it seems reasonable to request a generic extension to SBP-2 to address this issue. It is recommended that the following request be given to the committee working on the SBP-2 proposal and future revisions.

Use three of the reserved bits in the Login ORB and define them for a reconnect timeout negotiation field. The same number of bits needs to be defined in the Login Response structure for indicating the resulting reconnect timeout code. A value of zero is used to indicate the (default) of 1 second for backwards compatibility. If isochronous services are supported, the maximum value supported shall be zero. Reconnect timeout are configured from the following table. The value returned in the Login Response structure is the minimum value of what is requested by the initiator and the maximum of what is supported by the target.

Table XXX - Reconnect Timeout Code

Reconnect Timeout Code Field	Duration (seconds)
0_{16}	1
1_{16}	5
2_{16}	10
3_{16}	15
4_{16}	30
5_{16}	60 (1 min)
6_{16}	120 (2 min)
7_{16}	300 (5 min)